



Camshaft Phaser and Sprocket — RH

Special Tool(s)

 <p>ST2804-A</p>	Compressor, Valve Spring 303-1039
 <p>ST2869-A</p>	Locking Tool, Timing Chain 303-1175

Removal

NOTICE: This procedure must be followed exactly or damage to the valves and pistons will result.

1. Remove the RH valve cover. For additional information, refer to [Valve Cover — RH](#) in this section.
2. **NOTICE:** Damage to the camshaft phaser and sprocket assembly will occur if mishandled or used as a lifting or leveraging device.

NOTICE: Only use hand tools to remove the camshaft phaser and sprocket assembly or damage may occur to the camshaft or camshaft phaser and sprocket.

Loosen and backoff the RH camshaft phaser and sprocket bolt one full turn.

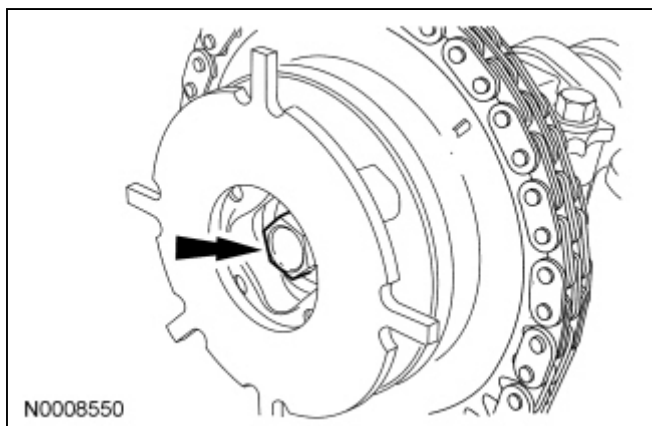

3. Disconnect the RH Camshaft Position (CMP) sensor electrical connector.

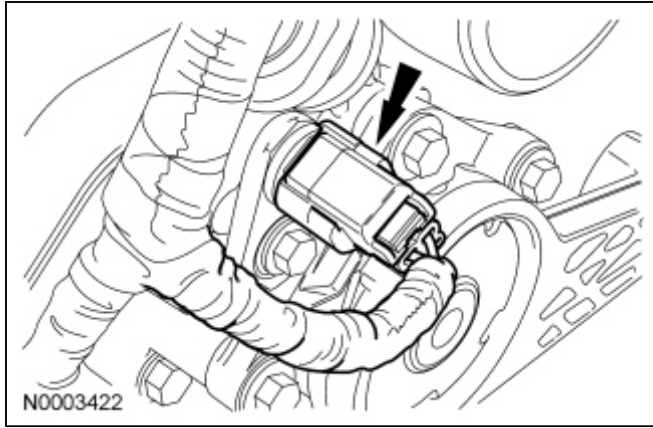

4. Remove the bolt and the RH [CMP](#) sensor.

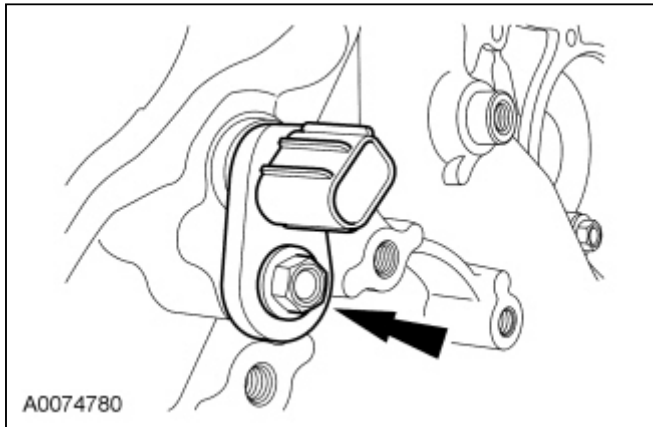

5. Rotate the crankshaft clockwise until the No. 1 cylinder camshaft exhaust lobe is coming up on the exhaust stroke and the 2 intake lobes are positioned between 10 and 11 o'clock as shown.

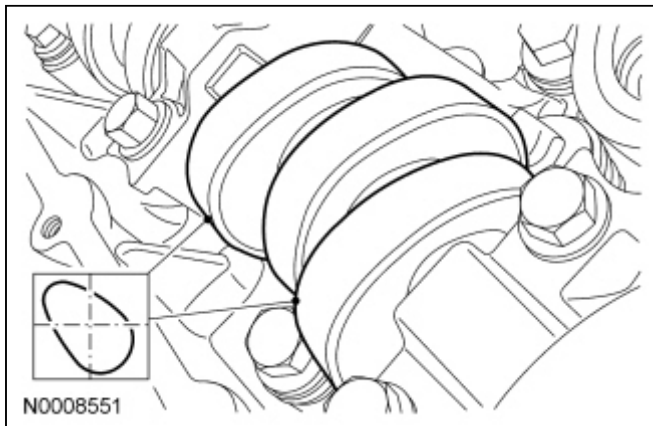

6. Remove only the 3 camshaft roller followers shown in the illustration.

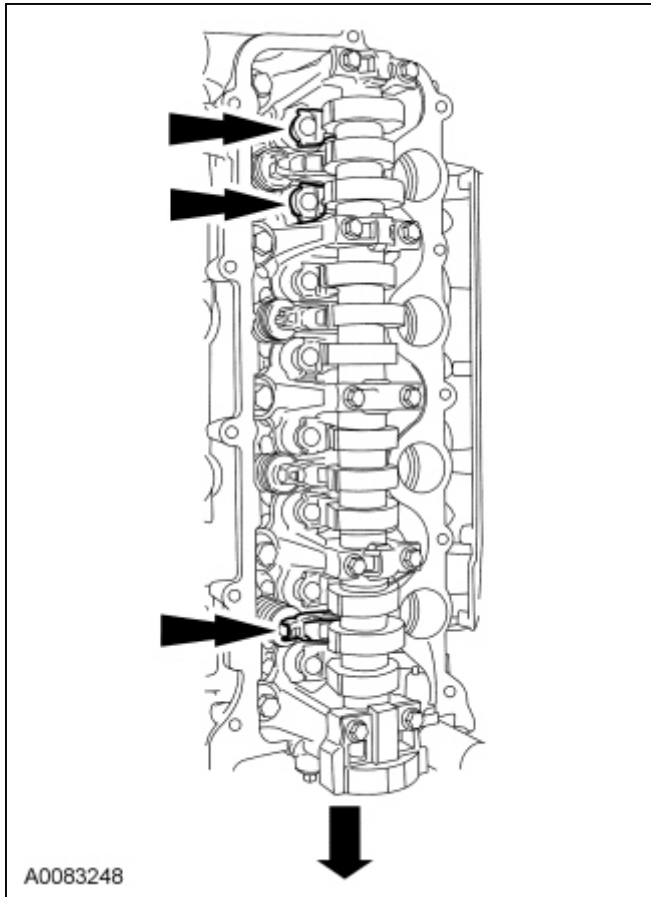

7. **NOTICE:** The camshaft roller followers must be installed in their original locations. Record camshaft roller follower locations. Failure to follow these instructions may result in engine damage.

NOTE: Do not allow the valve keepers to fall off of the valve or the valve may drop into the cylinder. If a valve drops into the cylinder, the cylinder head must be removed. For additional information, refer to [Cylinder Head](#) in this section.

NOTE: It may be necessary to push the valve down while compressing the spring.

Using the Valve Spring Compressor, remove only the 3 designated camshaft roller followers from the previous step.

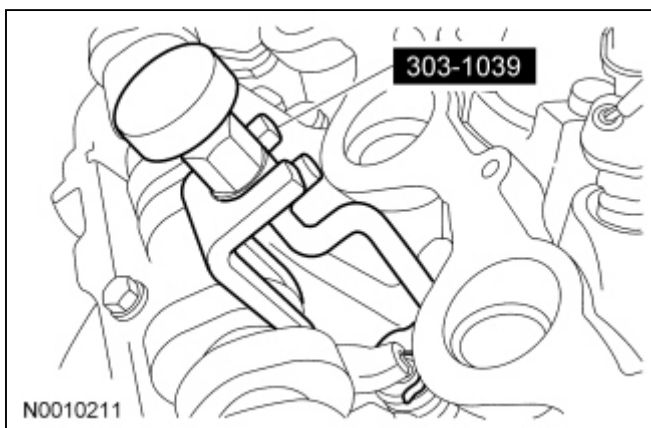

8. **NOTICE:** The crankshaft cannot be moved once set or engine damage may occur.

Rotate the crankshaft a half turn clockwise, as viewed from the front, positioning the No. 1 cylinder intake lobes at the 1 o'clock position as shown.

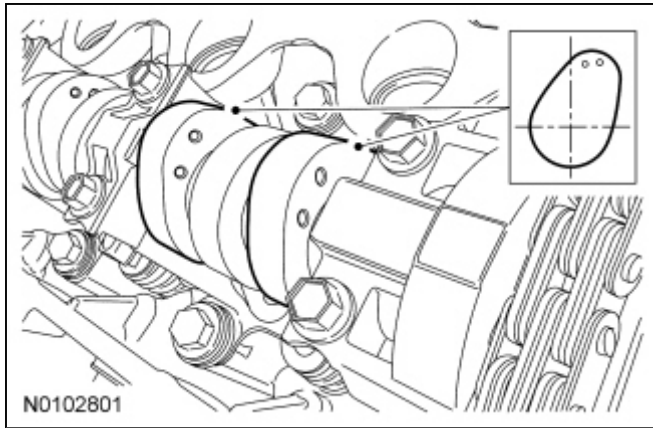

9. **NOTICE:** Engine is not freewheeling. Camshaft procedure must be followed exactly or damage to valves and pistons will result.

NOTE: The Timing Chain Locking Tool must be installed square to the timing chain and the engine block.

NOTE: Engine front cover removed for clarity.

Install the Timing Chain Locking Tool in the RH timing chain as shown.

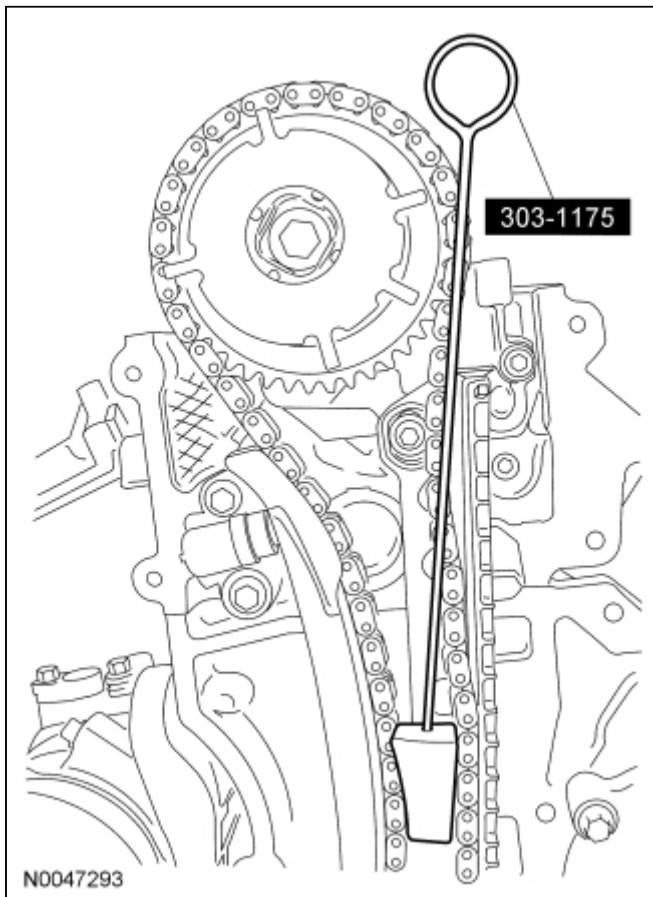

10. **NOTICE:** Do not remove the Timing Chain Locking Tool at any time during assembly. If the Timing Chain Locking Tool is removed or out of placement, the engine front cover must be removed and the engine must be retimed. For additional information, refer to [Timing Drive Components](#) in this section.

NOTICE: The timing chain must be installed in its original position onto the camshaft phaser and sprocket using the scribed marks, or damage to valves and pistons will result.

Scribe a location mark on the timing chain and the camshaft phaser and sprocket assembly.

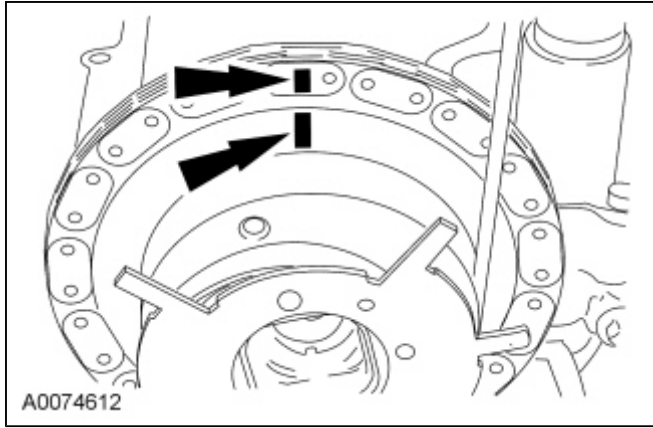

11. **NOTICE:** Damage to the camshaft phaser and sprocket assembly will occur if mishandled or used as a lifting or leveraging device.

NOTICE: Only use hand tools to remove the camshaft phaser and sprocket bolt or damage may occur to the camshaft or camshaft phaser and sprocket.

NOTICE: Do not remove the Timing Chain Locking Tool at any time during assembly. If the Timing Chain Locking Tool is removed or out of placement, the engine front cover must be removed and the engine must be retimed. For additional information, refer to [Timing Drive Components](#) in this section.

Remove the bolt and remove the camshaft phaser and sprocket assembly from camshaft and then from the timing chain.

- Discard the bolt and washer.

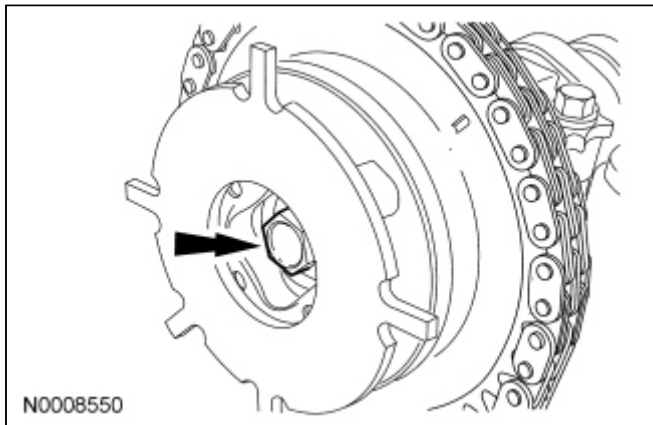

12. **NOTE:** If replacement of the camshaft phaser and sprocket is necessary, transfer the scribe mark to the new camshaft phaser and sprocket.

Inspect the camshaft phaser and sprocket for damage. For additional information, refer to [Section 303-00](#).

Installation

1. **NOTICE:** Do not remove the Timing Chain Locking Tool at any time during assembly. If the Timing Chain Locking Tool is removed or out of placement, the engine front cover must be removed and the engine must be retimed. For additional information, refer to [Timing Drive Components](#) in this section.

NOTICE: The timing chain must be installed in its original position onto the camshaft phaser and sprocket using the scribed marks, or damage to valves and pistons will result.

Position the camshaft phaser and sprocket into the timing chain with the timing chain scribe marks in alignment.

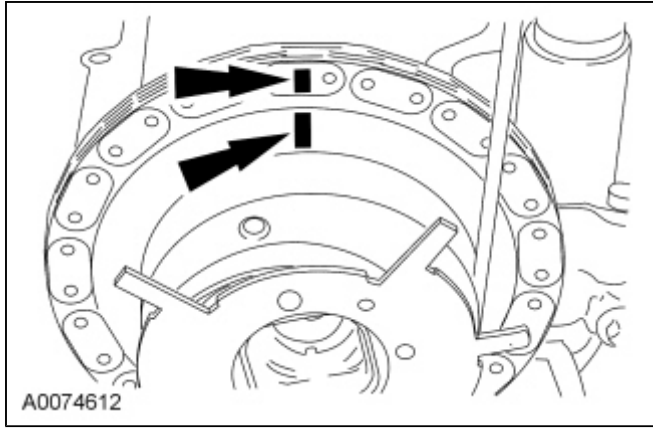

2. **NOTICE:** Do not remove the Timing Chain Locking Tool at any time during assembly. If the Timing Chain Locking Tool is removed or out of placement, the engine front cover must be removed and the engine must be retimed. For additional information, refer to [Timing Drive Components](#) in this section.

NOTICE: Damage to the camshaft phaser and sprocket assembly will occur if mishandled or used as a lifting or leveraging device.

NOTICE: Only use hand tools to install the camshaft phaser and sprocket bolt or damage may occur to the camshaft or camshaft phaser and sprocket.

Position the camshaft phaser and sprocket assembly onto the camshaft. Install a new camshaft phaser and sprocket bolt finger-tight.

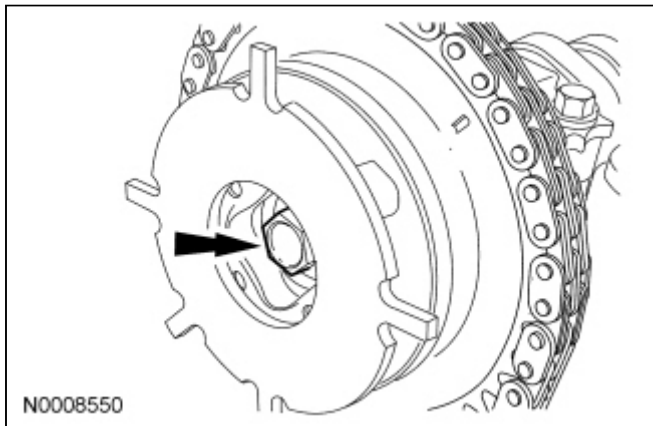

3. **NOTE:** Engine front cover removed for clarity.

Remove the Timing Chain Locking Tool.

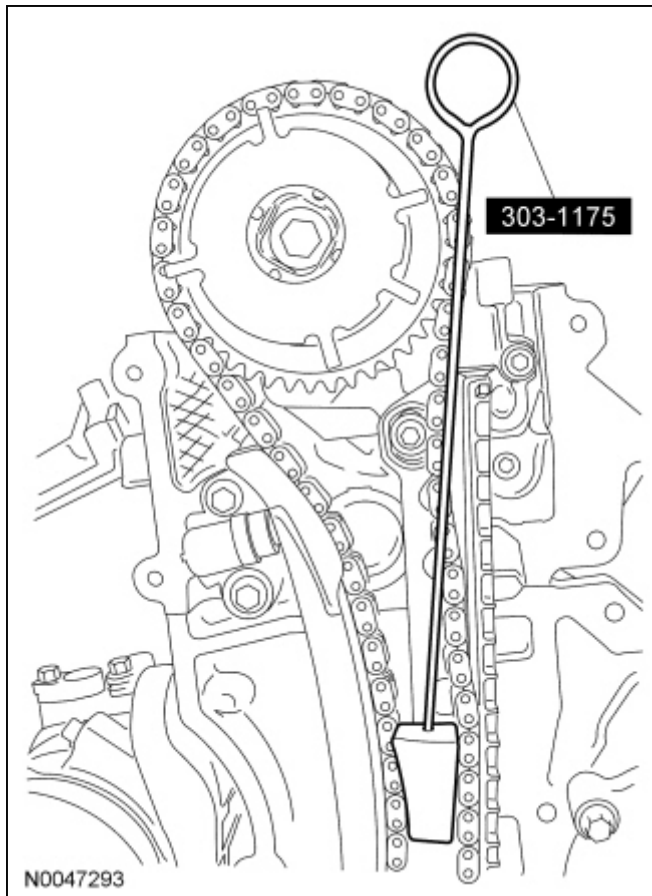

4. Rotate the crankshaft a half turn counterclockwise until the No. 1 cylinder camshaft intake lobes are positioned between 10 and 11 o'clock as shown.

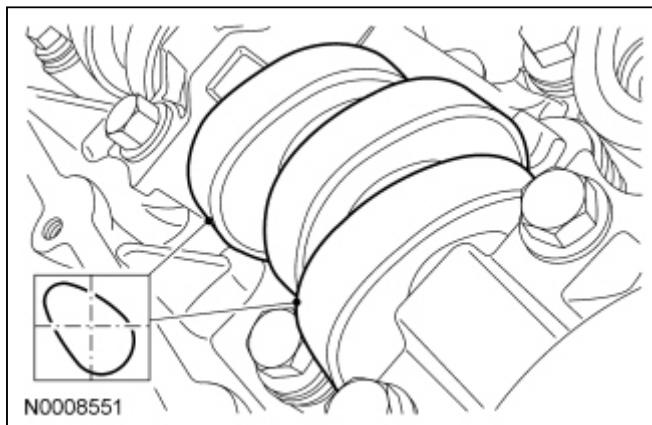

5. **NOTE:** Do not allow the valve keepers to fall off of the valve or the valve may drop into the cylinder. If a valve drops into the cylinder, the cylinder head must be removed. For additional information, refer to [Cylinder Head](#) in this section.

NOTE: It may be necessary to push the valve down while compressing the spring.

Using the Valve Spring Compressor, install the 3 originally removed camshaft roller followers.

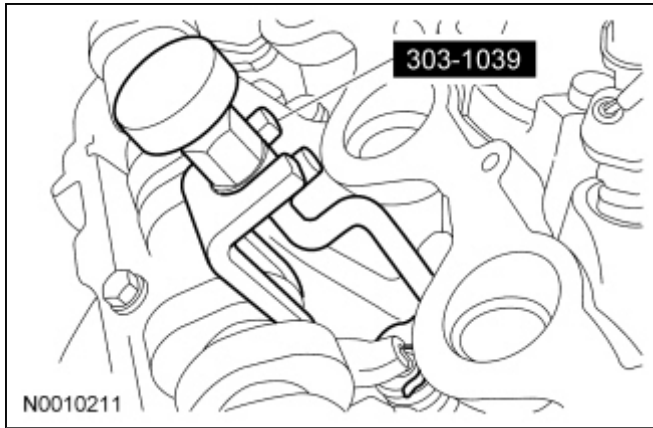

6. Install the **CMP** sensor and the bolt.
 - Tighten to 10 Nm (89 lb-in).

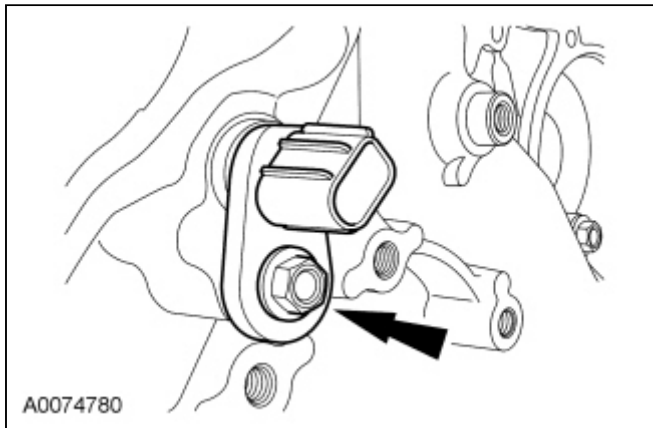

7. Connect the **CMP** electrical connector.

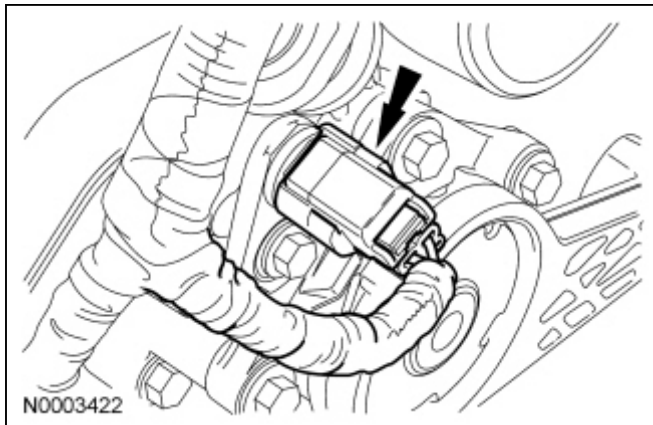

8. **NOTICE:** Only use hand tools to install the camshaft phaser and sprocket assembly or damage may occur to the camshaft or camshaft phaser and sprocket.

NOTICE: Damage to the camshaft phaser and sprocket assembly will occur if mishandled or used as a lifting or leveraging device.

Tighten the new camshaft phaser and sprocket bolt in 2 stages:

- Stage 1: Tighten to 40 Nm (30 lb-ft).
- Stage 2: Tighten an additional 90 degrees.

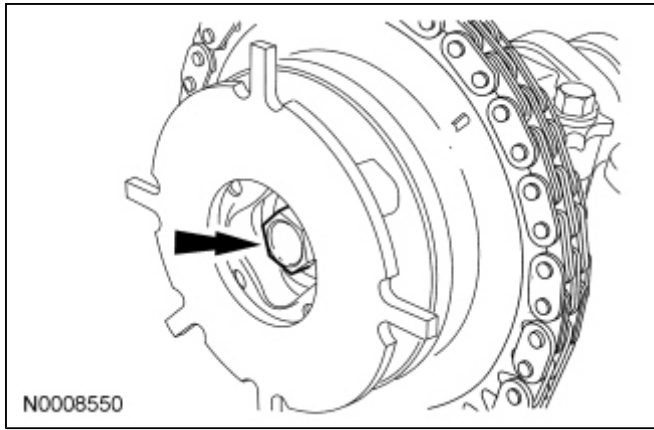

9. Install the RH valve cover. For additional information, refer to [Valve Cover — RH](#) in this section.
-